

» H2 hard shoulder

H2BL1000

components

- Thrie W Beam 5333 mm th. 2,5 mm;
- "C" Section Post 30x80x120 mm th. 5,0 mm
H = 1750 mm c/c 2666,6 mm;
- "U" Spacer th. Mm 3;
- Stiffner for "C" Post;
- Adjusting setting plate;
- Unthreading proof little plate;
- Bolts and Nuts;
- Reflector (n° 1 every 16 m).

This Barrier provides, for each section of barrier, the installation mitred Approach/Escape modules for a total length of 19,17 m (9,585 for Approach+ 9,585 for Escape)

section

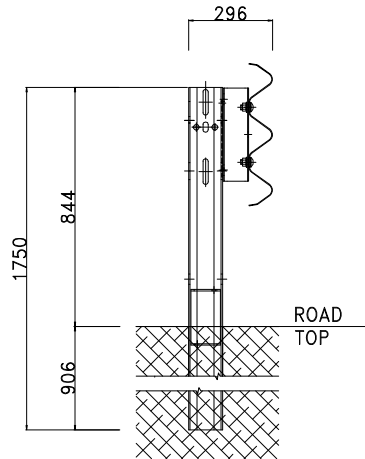

- Dwg. n.: H2BL1000
c/c distance between the posts: 2.666,6 mm

performance

TB11 - Car 900 kg

Test: 905
ASI: A - 0,9

TB51 - Bus 13.000 kg

Test: 904
W_N: m 1,3 (W4)
D_N: m1,20
V_N: m 1,50 (VI5)

FRONT
VIEW

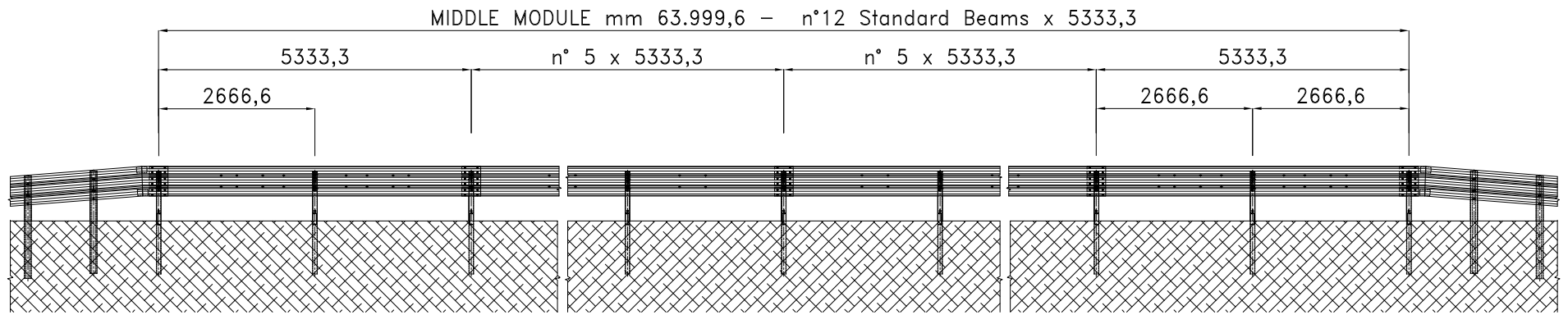

TRAFFIC DIRECTION (Impact on the left) →

TOP
VIEW

