

➤ H2 hard shoulder

H2BL1200

components

- 3W Beam 5333 mm th. 2,5 mm;
- "C" Section Post 30x80x120 mm th. 5,0 mm
H = 1750 mm c/c 2133,2 mm;
- Connection Element (Beam/Post);
- Stiffner for "C" Post;
- Unthreading proof little plate;
- Bolts and Nuts;
- Reflector (n° 1 every 10,66 m).

This Barrier provides, for each section of barrier, the installation of Approach/ Escape End Section modules for a total length of 27,00 m (13,50 for Approach+ 13,50 for Escape)

section

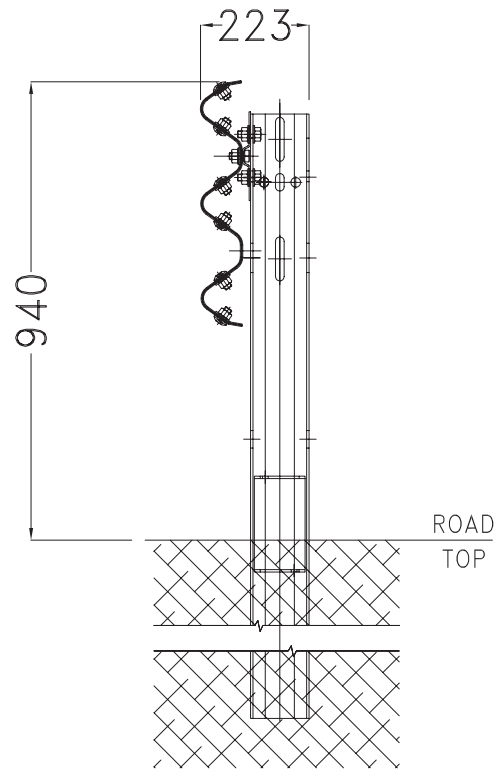

- Dwg. n.: **H2BL1200**
c/c distance between the posts: **2.133 mm**

performance

TB11 - Car 900 kg

Test: 1274
ASI: A - 0,8

TB51 - Bus 13.000 kg

Test: 1273
W_N: m 1,0 (W3)
D_N: m 0,9
V_N: m 1,0 (VI3)

FRONT VIEW

mm 90999,6

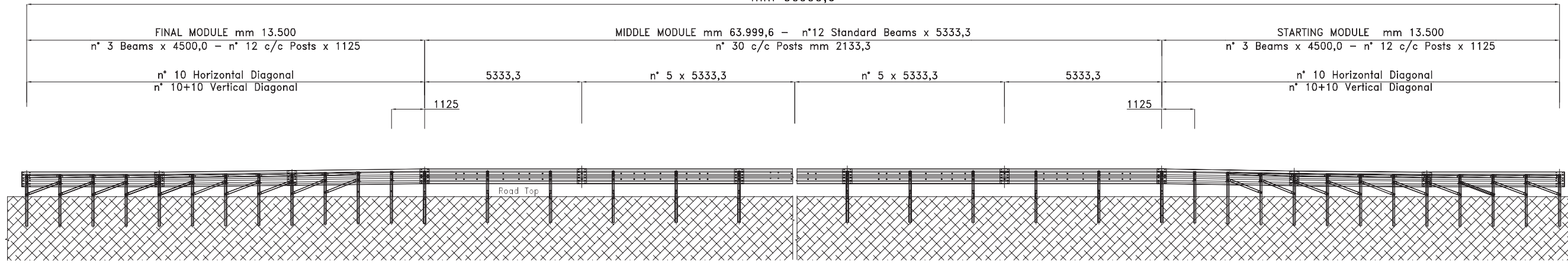

← TRAFFIC DIRECTION (Impact on the Right)

TOP VIEW

